

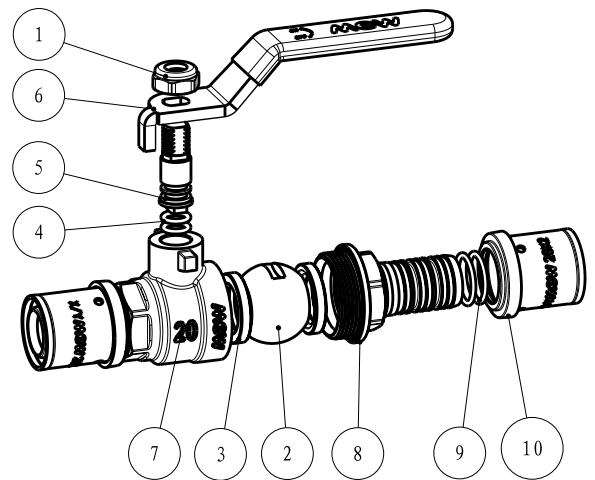

Ficha Técnica

PRESS Multicamada
Válvula Linha
20 MW09032502

ESCOLHA DE PROFISSIONAL

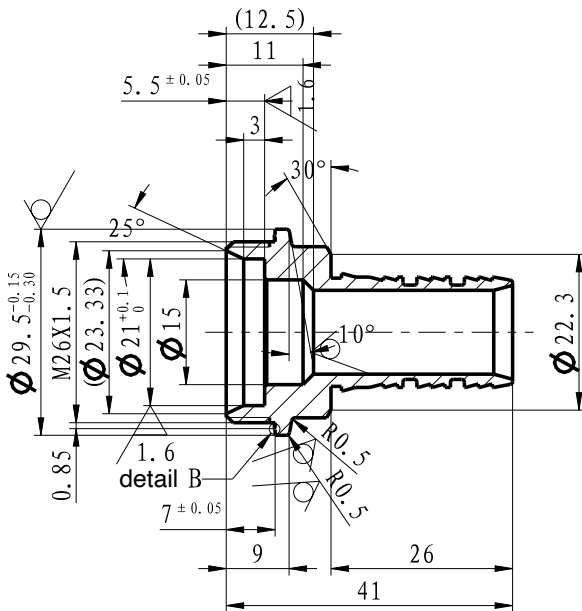
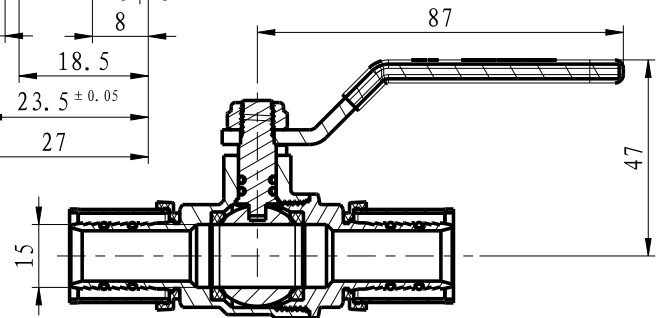
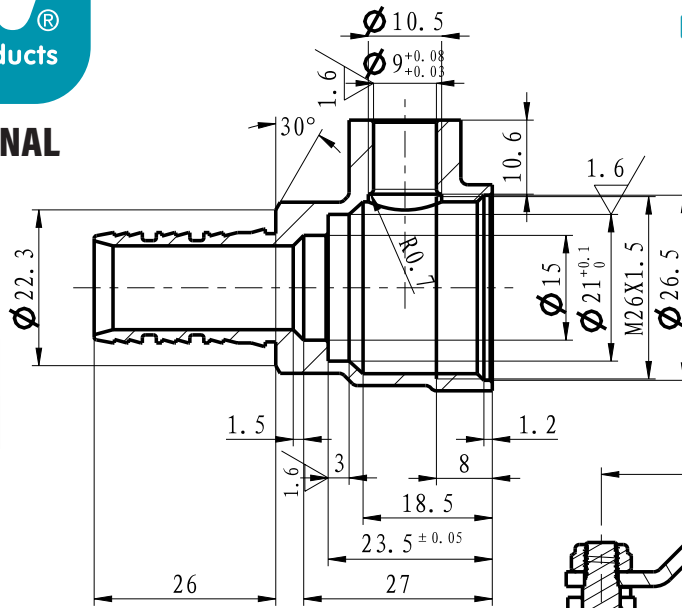

Legenda e componentes:

Número	Componente	Material
1	Parafuso	Q235A
2	Esfera	HPB57-3
3	Acento	PTFE
4	Vedação	EPDM
5	Corpo	CW617N
6	Canpânula	CW617N
7	Vedação	EPDM
8	Haste	HPB57-3
9	Manipulo	Q235
10	Casquilho	S304

Características técnicas:

1. Peso: 233 gr



ESCOLHA DE PROFISSIONAL

Ficha Técnica

PRESS Multicamada
Válvula Linha
25 MW09032503

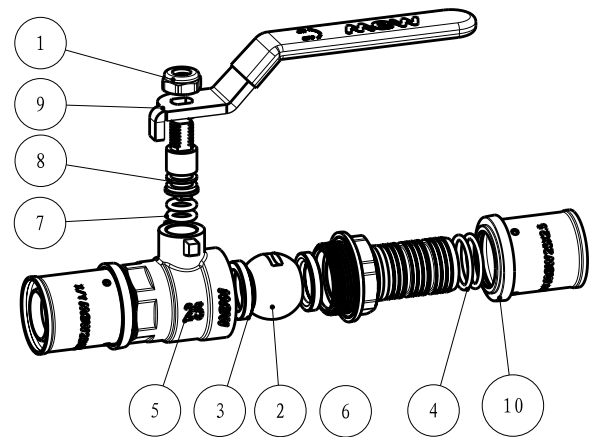
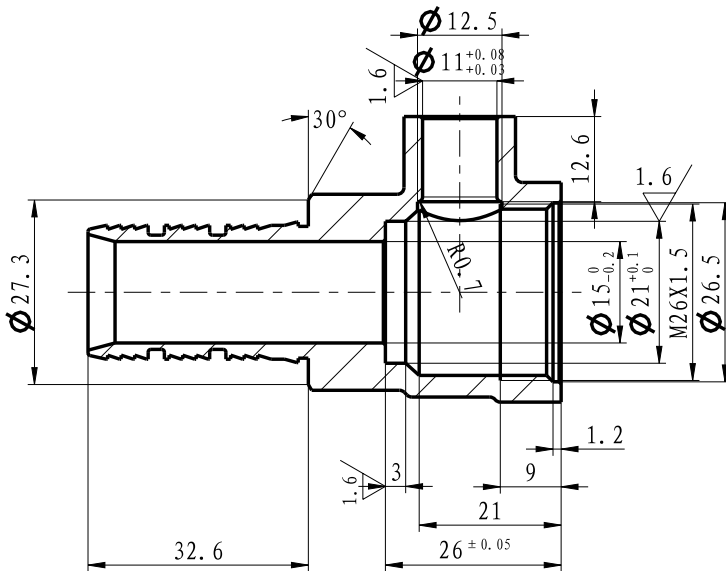
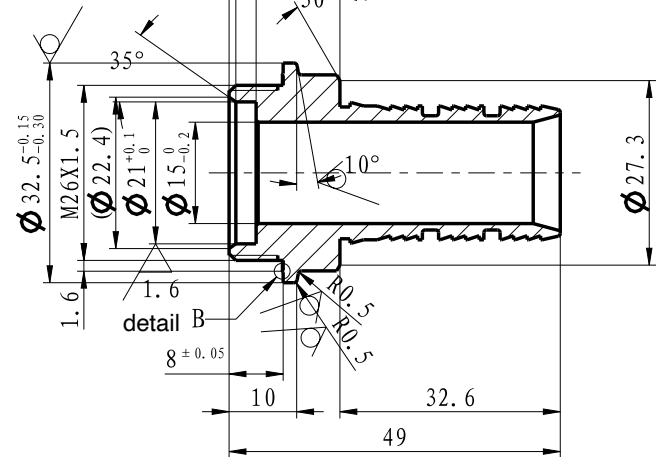
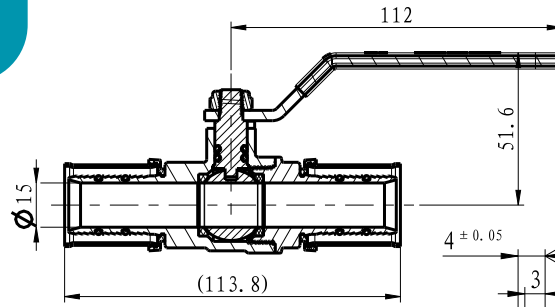

Legenda e componentes:

Número	Componente	Material
1	Parafuso	Q235A
2	Esfera	HPB57-3
3	Acento	PTFE
4	Vedação	EPDM
5	Corpo	CW617N
6	Canpânula	CW617N
7	Vedação	EPDM
8	Haste	HPB57-3
9	Manipulo	Q235
10	Casquilho	S304

Características técnicas:

1. Peso: 370 gr



Ficha Técnica

PRESS Multicamada
Válvula Linha
32 MW09032504

ESCOLHA DE PROFISSIONAL

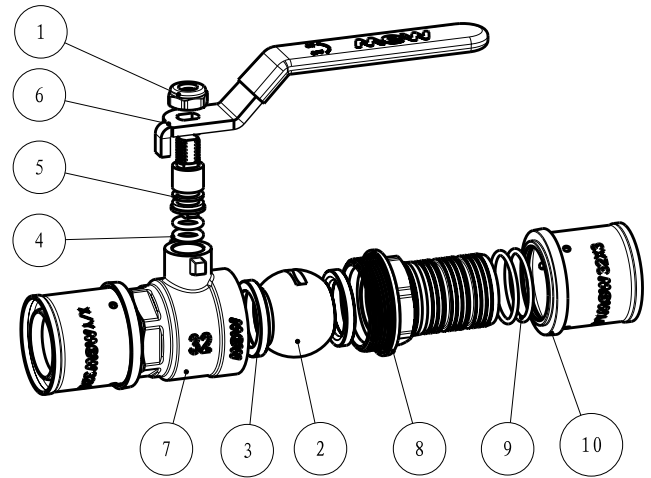
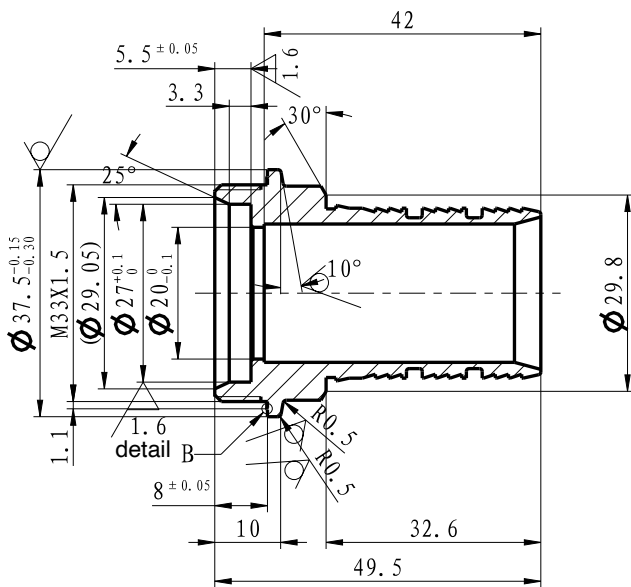
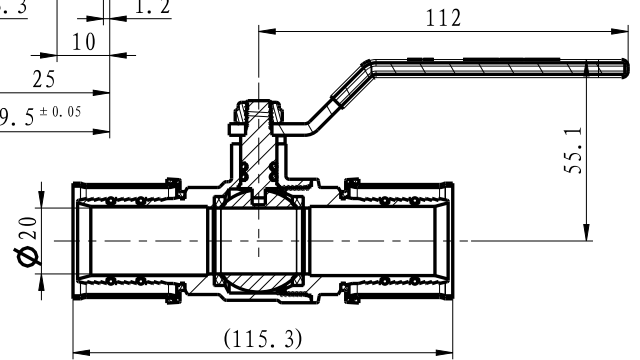
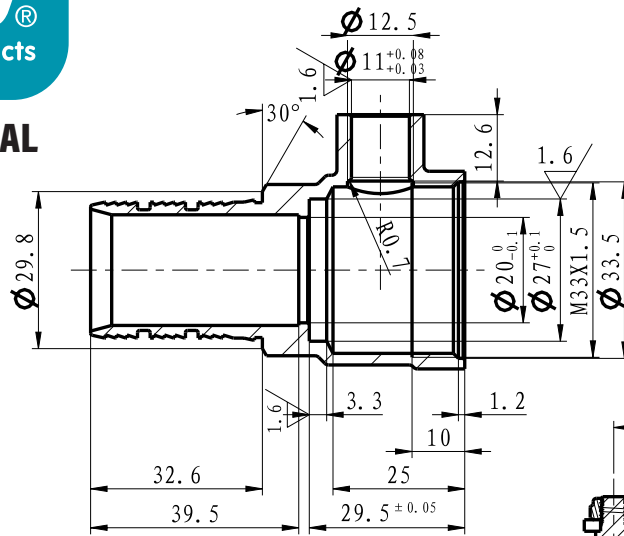
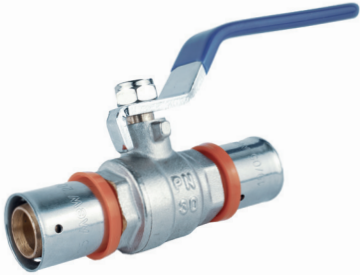

Legenda e componentes:

Número	Componente	Material
1	Parafuso	Q235A
2	Esfera	HPB57-3
3	Acento	PTFE
4	Vedação	EPDM
5	Corpo	CW617N
6	Canpânula	CW617N
7	Vedação	EPDM
8	Haste	HPB57-3
9	Manipulo	Q235
10	Casquilho	S304

Características técnicas:

1. Peso: 427 gr