

ART.3015	
<i>Connecting coupler, Mis. from Ø20 to Ø110</i>	
SPECIFICATION	
Series	3015
Thread ends	PIPE-PIPE: PE
Orifice	from Ø20 to Ø110 mm
Actuator	-
Operator	-
APPLICATION	
Assembly in rigid pipe system	
Nominal pressure (PN) in bar:30	
KV: flowrate coefficient m ³ /h	
Direction of flow:as desired	
Temperature range: -20 °C / +80°C	
Use:Gas-Water	

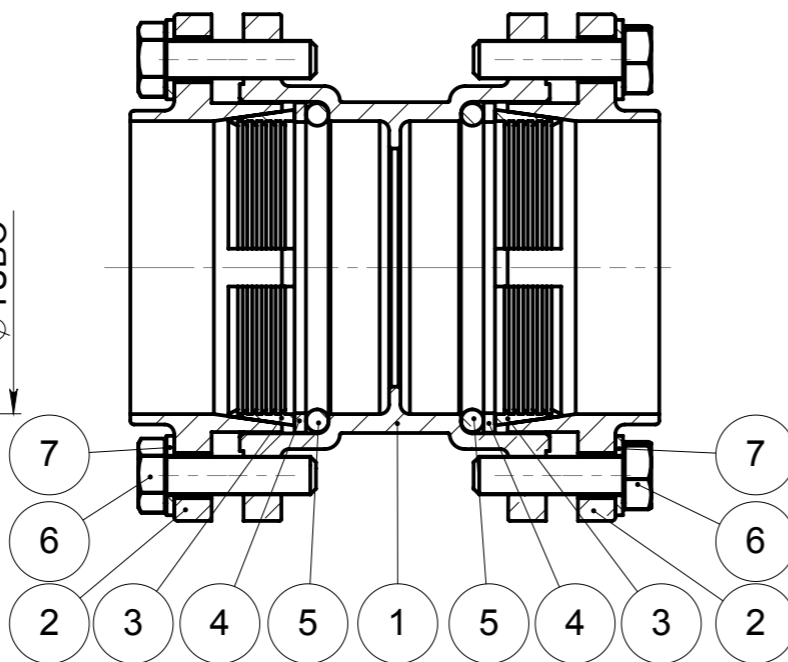
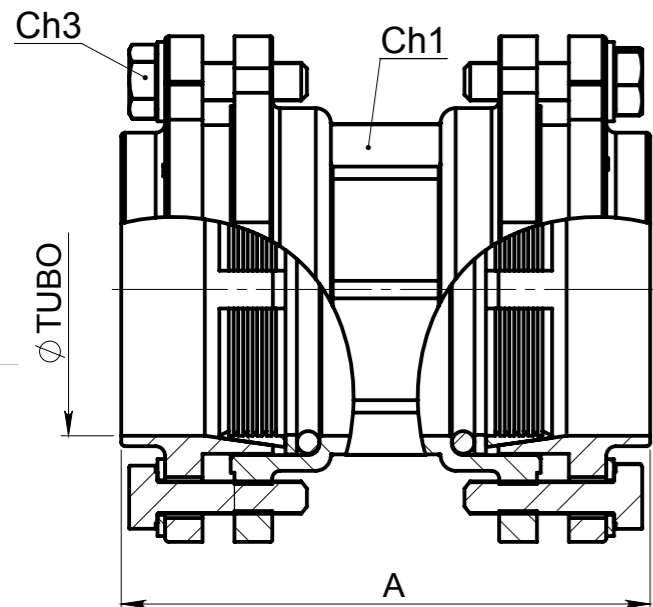

(*) la misura da DN20 è in materiale CW617N

N°	Descrizione	Description	Materials	Q.ty
1	Corpo raccordo	Body coupler	CW617N	1
2	Dado	Nut	CW602N (*)	2
3	Ghiera	Compression ring	CW614N	2
4	Rondella	Brass Ring	CW614N	2
5	O-Ring	O-Ring	01/B70 NBR	2

N°	Descrizione	Description	Materials	Q.ty
6	Vite	Screw	AISI 304	8
7	Rondella	Ring	AISI 304	8

ØTUBO	A	Ch1	Ch2	Ch3	PN
20	61	25	34	-	30
25	66.5	30	39	-	30
32	79	37	48	-	30
40	105.5	45	58	-	30
50	108.5	56	69	-	30
63	119.5	69	82	-	30
75	140	82	-	17	30
90	162	98	-	17	30
110	210	120	-	17	30

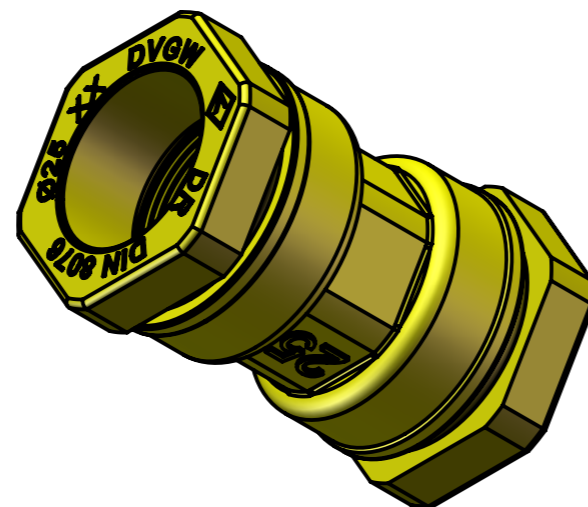

Misure: da Ø75 a Ø110 sono flangiate

Denominazione particolare / Name Manicotto di accoppiamento		Disegnato / Designed by Pedretti Walter	Formato / Format A3	Grezzo / Forged Code	Quote senza indicazione di tolleranza: MEDIA UNI-ISO 2768/1
Materiale / Material		Approvato / Approved by	Scala / Scale 1:1	Lavorato / Finished Code	Rugosità Generale $\sqrt{3.2}$ ($\sqrt{0.7}$) General Roughness
Tratt. Superficiale / Surface Treat. Tratt.Termico / Thermal Treat.		Data / Date 17/01/2012	Foglio / Tab. 1/1	Trattato / Treaty Code	A termini di legge questo disegno è di proprietà della BUGATTI VALVOSANITARIA Spa e non può essere copiato,riprodotto e divulgato senza nostra autorizzazione scritta.
N° Disegno / Drawing Nr. 3015		Revisione / Revision -	Peso / Weight -	Valido per / Available for Consultazione	This print is property of BUGATTI VALVOSANITARIA Spa and must not be used in any manner unless prior written authority is received.
		Misura / Size g Ø20-Ø110		BUGATTI VALVOSANITARIA UFFICIO TECNICO	